



ADDITIONS AND ALTERATIONS

Neighborhood
Services

Effective: May 25, 2017
Revised: January 26, 2024

Additions and Alterations:

- (3) sets - Architectural, existing and proposed floor plan, and structural (including all plumbing, electrical, and mechanical). Minimum plan size is 11"x17".
- (2) sets - Structural calculations
- (2) sets - Energy calculations
- (1) - Permit Submittal Form

Plot plan

Correctly dimensioned property lines with bearings
Set-back dimensions
Fence location and height

Architectural

Floor plan (existing and proposed)
Roof plan
Exterior elevations
Sections, details, notes

Structural

Foundation plan
Floor framing plan
Roof framing plan
Truss calculations w/letter from S.E.
Cross section
Structural framing details

Electrical / Plumbing / Mechanical

Location and size of service, switches, lights and outlets
Location and size of electrical sub-panels
Location of plumbing fixtures
Mechanical ventilation system
T-24 energy calculations

Other Documents

Fire Sprinkler Plans (**MUST SUBMIT SEPARATELY TO CONTRA COSTA COUNTY FIRE PROTECTION DISTRICT**) -
4005 Port Chicago Hwy, Concord, CA
(925)941-3300

APPLICABLE CODES AS OF JANUARY 1, 2023

- 2022 California Building Code (CBC)
- 2022 California Plumbing Code (CPC)
- 2022 California Mechanical Code (CMC)
- 2022 California Electrical Code (CEC)
- 2022 California Green Building Standards (CalGreen)
- 2022 California Energy Code (Title 24)
- Brentwood Municipal Code

The City of Brentwood participates in the Green Halo Recycling program.

- Recycling Waste Management Plan – Green Halo – 1 888-525-1301 - www.greenhalosystems.com

- All residential projects with a valuation of \$75,000 or greater will be required to create an account with Green Halo and provide an application # prior to permit issuance
- Recycling receipts are required to be uploaded to Green Halo and will be reviewed/approved by the city prior to final inspection

EXAMPLE PLOT PLAN

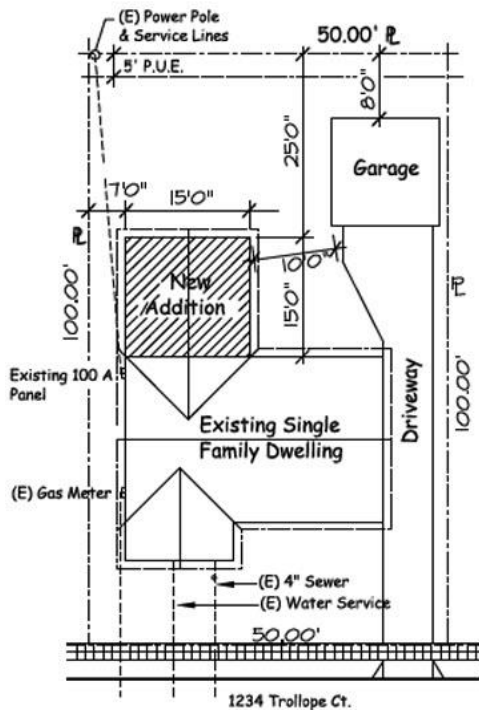

EXAMPLE FLOOR PLAN

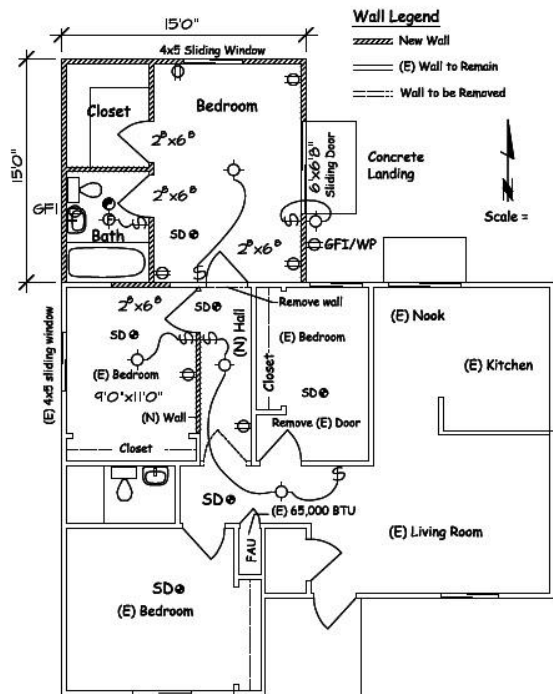

EXAMPLE FRAMING PLAN

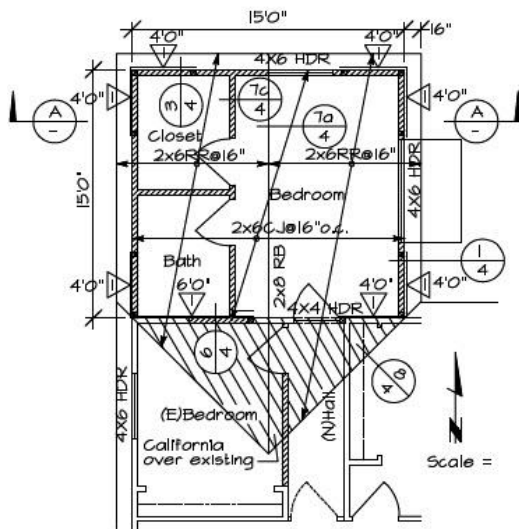

EXAMPLE CONSTRUCTION SECTION

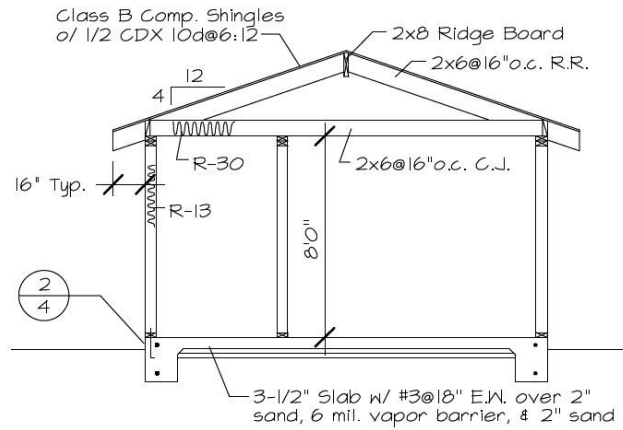

FRAMING SECTION A-A

EXAMPLE ELEVATIONS

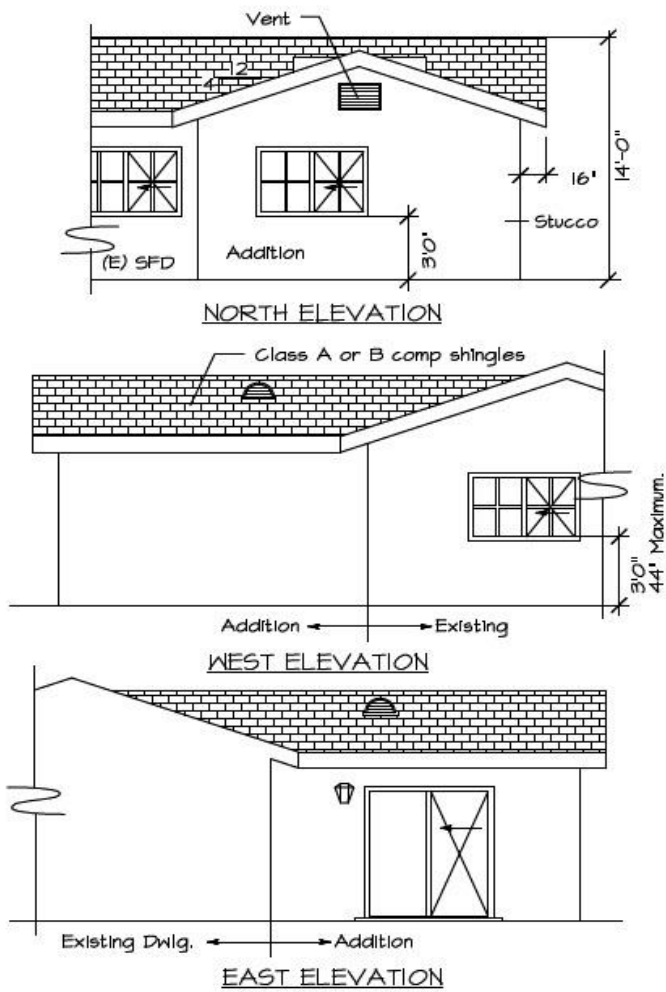

EXAMPLE FOUNDATION PLAN

