7:00 P.M. – PARK AND RECREATION COMMISSION

IMPORTANT NOTICE ABOUT PUBLIC COMMENTS AND MEETING PARTICIPATION

UPDATED FEBRUARY 17, 2022

Consistent with Contra Costa County Health orders, and in accordance with California Government Code Section 54953(e) concerning teleconference meetings, this Brentwood Neighborhood Committee meeting will be held exclusively via teleconference, using the Zoom video conferencing system. At this time, public participation will be available exclusively via telephone or teleconference, using the Zoom video conferencing system.

How to View & Participate

As the Council Chamber will not be open, the public may both view and participate in the Park and Recreation Commission meeting via Zoom at: <https://www.brentwoodca.gov/ParkRecCommissionMeetingOnline>

The public is invited to participate in the Park and Recreation Commission meeting and offer comments of up to 3 minutes (or as may otherwise be determined by the Park and Recreation Commission) using any of the following methods:

1. Zoom: <https://www.brentwoodca.gov/ParkRecCommissionMeetingOnline>

During the meeting, each period for public comment will be announced, and participants may use the “Raise Hand” feature on Zoom to request to speak. The meeting host will call on you, by name, and enable your video, if desired to be enabled, and microphone when it is your turn to speak. In order to ensure the orderly administration of the meeting using this method, providing your name is encouraged, but is not required. *(If you need instructions on how to use this feature, please contact Aaron Wanden, Park Maintenance Manager, by noon of the meeting date at awanden@brentwoodca.gov or 925.516.5111.)*

2. Telephone

If you wish to comment during the meeting via telephone, you may “raise your hand” virtually on most devices by pressing *3, and you will be called upon when it is your time to speak. After speaking, please press *3 again to remove the “raise your hand” feature. If that feature does not work on your device, please email awanden@brentwoodca.gov in advance of the meeting where possible. The request must contain in the subject line “Request to Speak – Agenda Item #” and should include name and full phone number that will be used to call in. In order to ensure the orderly administration of the meeting using this method, providing your name is encouraged, but is not required.

3. E-mail

While the County Health order to shelter at one’s place of residence is effective, public comments can also be submitted via e-mail to awanden@brentwoodca.gov. Emails not sent to this email address will not be included as public comments. Any public comments received up until 3:00 p.m. of the meeting date will be:

- distributed to the Commission via email before the meeting,
- posted online for public inspection at <https://www.brentwoodca.gov/gov/boards/parks/pcpc.asp> and
- later summarized in the meeting minutes.

Public comments received after 3:00 p.m. of the meeting date, but prior to the start of the meeting, will be emailed to the Commission, posted online within one day following the meeting and will be summarized in the meeting minutes.

The City cannot guarantee that its network, website, and/or the Zoom system will be uninterrupted. To ensure that the Park and Recreation Commission receives your comments prior to taking action, **you are strongly encouraged to submit them in advance of the meeting by 3:00 p.m.**

As e-mails containing public meeting comments are part of the official record, note that personal contact information may be published if it is included with your e-mail. In addition, any other disclosable public records related to an agenda item for the open session of this meeting distributed to all or a majority of the Park and Recreation Commission less than 72 hours before any meeting will be made available online shortly thereafter.

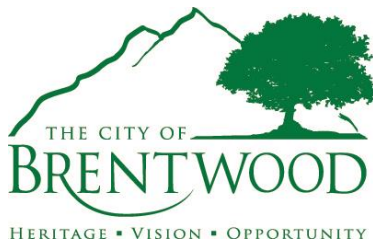

APRIL 28, 2022
PARK AND RECREATION COMMISSION AGENDA
VIA ZOOM

7:00 P.M. – PARK AND RECREATION COMMISSION

CALL TO ORDER & ROLL CALL

PLEDGE OF ALLEGIANCE

PUBLIC COMMENTS At this time the public is permitted to address the Park and Recreation Commission on items that are on the Consent Calendar, Requests for Future Agenda Items, or items **not** on the agenda. Persons addressing the Park and Recreation Commission are required to limit their remarks to three (3) minutes unless an extension of time is granted by the chair subject to approval of the Park and Recreation Commission. Please file your name with the chair on the form provided at the podium. Speakers desiring answers to questions should direct it to the Park and Recreation Commission and, if relevant, the Park and Recreation Commission may direct it to the appropriate staff member.

A. INFORMATIONAL REPORTS FROM COMMISSIONERS, SUBCOMMITTEES, LIAISONS AND STAFF This portion of the agenda is to provide an opportunity for each Commissioner to report on attendance at events, subcommittee meetings, and entities on which the Commissioner has been appointed as a liaison and for staff to provide brief updates and/or information to the Park and Recreation Commission.

B. CONSENT CALENDAR All matters listed on the consent calendar are considered routine in nature and will be enacted by one motion. If discussion is required, that particular item will be removed from the consent calendar and will be considered separately.

1. Approve minutes of Regular Meeting of March 24, 2022.
2. Accept Parks Division Quarterly Report. (B. Johnson)
3. Accept Maintenance Division Quarterly Report. (M. Azamey)
4. Accept Landscape Division Quarterly Report. (J. Coll)

C. NEW BUSINESS

1. **DISCUSS/ACTION ITEM** Discuss and consider approval of Sunset Park Athletic Complex change of hours of operation and any additional relative considerations. (A. Wanden/K. Farro)
2. **ACTION ITEM** Approve the formation of an ad-hoc committee for Creekside Pickleball Court CIP Project #352-52441. (J. Odrzywolski)
3. **ACTION ITEM** Approve the formation of an ad-hoc committee for the Sand Creek Sports Complex project. (J. Odrzywolski)
4. **ACTION ITEM** Provide direction to staff regarding the park acreage requirement for the 7590 and 7650 Lone Tree Way project, Subdivision 9597, a proposed 38-lot single-family residential subdivision. (J. Odrzywolski)

D. REQUEST FOR FUTURE AGENDA ITEMS

I. COMMISSION REQUESTED ITEM(S) The Park and Recreation Commission may have a brief discussion of the requested item and upon concurrence by the majority of the membership of the Park and Recreation Commission present that staff time and City resources be spent on an item, it shall be scheduled for a future meeting. The Commission will take no other action on the listed items. Commission concurrence that staff time or City resources be spent on an item does not signify approval of a particular item, just that the Commission wishes to have it studied further and the Commission may, at a future time, decide not to pursue the item further.

II. NEW REQUEST(S) Park and Recreation Commissioners wishing to have an agenda item placed on a future agenda shall make a request under this section of the agenda. These items will be included on the agenda for the next Park and Recreation Commission meeting.

ADJOURNMENT

NOTICE

Any disclosable public records related to an agenda item for the open session of this meeting distributed to all or a majority of the Park and Recreation Commission less than 72 hours before this meeting is available for inspection at City Hall, located at 150 City Park Way, during normal business hours. These writings will also be available for review at the Park and Recreation Commission meeting in the public access binder in the entrance of the City Council Chambers.

NOTICE

In compliance with the Americans with Disabilities Act, the meeting room is wheelchair accessible and disabled parking is available at the City Hall parking lot. If you are a person with a disability and you need disability-related modifications or accommodations to participate in this meeting, please contact the City Clerk's Office at (925) 516-5440 or fax (925) 516-5441. Notification 48 hours prior to the meeting will enable the City to make reasonable arrangements to ensure accessibility to this meeting. {28 CFR 35.102-35, 104 ADA Title II}

POSTING STATEMENT

On April 25, 2022 a true and correct copy of this agenda was posted on the City Hall Bulletin Board, outside City Hall, 150 City Park Way, Brentwood, CA 94513 and at the Community Center Bulletin Board outside the Community Center, 35 Oak Street, Brentwood, CA 94513 and at our website www.brentwoodca.gov



PARK & RECREATION COMMISSION REGULAR MEETING

CALL TO ORDER: Chair Frey called the meeting to order at 7:00 p.m.

ROLL CALL: Chair Trevor Frey, Vice-Chair Kevin Peltz and Commissioners Noman Cohen and Blythe Lind were present. Commissioner Bullington was excused. Staff members present were Kris Farro, Recreation Manager, Joe Odrzywolski, Parks Planner; Aaron Wanden, Park Maintenance Manager; Jason Coll, Park Maintenance Supervisor and Elaine McGurk, Administrative Supervisor.

A. PRESENTATIONS:

1. Eagle Scout Project by Patrick Breves. (J. Coll)

Jason Coll, Park Maintenance Supervisor, introduced an Eagle Scout Project by Patrick Breves. Patrick Breves, a Boy Scout, presented his Eagle Scout Project to the Commission. He plans to plant three 15-gallon Chinese Pistache trees outside Veterans Hall on First Street. There will also be flowers added to areas around the building that are barren.

PUBLIC COMMENTS: NONE

B. INFORMATIONAL REPORTS FROM COMMISSIONERS, SUBCOMMITTEES, LIAISONS AND STAFF

Commissioner Lind attended two ad-hoc committee meetings (Arbor Day & Restrooms at Creekside & Garin Park).

Vice-Chair Peltz attended two ad-hoc committee meetings (Restrooms at Creekside & Garin Park and Parkside Villas)

Commissioner Cohen attended the Arbor Day ad-hoc committee meeting with Commissioner Lind and Jason Coll.

Joe Odrzywolski, Parks Planner reported the following:

- On March 8, 2022, Towhee Park went to City Council for acceptance of park and landscaping improvements.
- The Vineyard Project is moving along swiftly. Aspen and Monte Rosa Parks are in the 90-day maintenance period and will be accepted in early July.
- At Alta Park, the hardscape and play structure will be installed in the next few weeks.
- Shea Homes will begin to start a section of trail that will connect to the Marsh Creek Trail.

Aaron Wanden, Park Maintenance Manager, gave an update on an email received in regards to adding dog wastebaskets on the corners of Garin Parkway/Chestnut Street and Garin Parkway/Balfour Road. Aaron said staff is reviewing the matter and will determine if it would be feasible.

Kris Farro, Recreation Manager Reported the following:

- Sports and Adult Softball are active and in full swing.
- Bingo at the Senior Center will return. This activity is in partnership with the Brentwood Senior Club. At this time, the Senior Club Board is requesting for proof of vaccination and not a requirement of the City.
- The Contra Costa Nutrition Food program CC Café changed its name to Café Costa. They started something new on Tuesday and Thursday, they are serving food from Chapala Restaurant. They are trying to be culturally inclusive with the type of meals served. With more funding, they hope to include a diverse array of foods.
- Arts Commission approved for seven new utility boxes art projects and a Call for Artwork at the Library is out.
- Brentwood Community Center will be getting the carpet replaced.
- Summer 2022 Activities Guide will be out in the next couple of weeks.
- Concerts in the Park will be back this summer.
- On March 29th the new City website will go live.
- Recreation is hiring for seasonal and part time positions.

C. **CONSENT CALENDAR**

All matters listed on the Consent Calendar are considered routine in nature and will be enacted by one motion. If discussion is required, that particular item will be removed from the Consent Calendar and will be considered separately.

1. Approve minutes of Regular Meeting of February 24, 2022.
2. Approve Proclamation designating April 30, 2022 as Arbor Day and recommend to City Council for acceptance at the April 26, 2022 meeting.

❖ Motion to approve consent calendar items 1 and 2.

Motion: Lind
Second: Peltz
Ayes: 4 (Cohen, Frey, Lind, Peltz)
Noes: 0
Excused: 1 (Bullington)

D. **SCHEDULED MATTERS**

1. **INFORMATIONAL ITEM:** Staff update on the BETC/BSAC Conceptual Plan Study. (K. Farro)

Kris Farro, Recreation Manager, introduced the item. A bid for architectural firm went out to evaluate the Brentwood Technology Center for a possible Youth Center and the Expansion of the Senior Center. Dreyfuss & Blackford was selected and after some structural & seismic assessment at the Brentwood Technology Center, it was determined that many modifications would need to be made. There is not enough ceiling height to transform the building into a gymnasium. The Brentwood Technology Center will not be a possible site for a Youth Center.

A survey went out to the youth and the parents of the youth to inquire what desires they have for a youth center. Some things they would like to see are academic activities, a lounge area, a cooking space, a place to do art, a gaming area, and recreation area.

The Expansion of the Senior Center and Youth Center will be included on a long-term project list. The City Council has moved the Sand Creek Sports Center to the top of the strategic initiatives list.

The City Council is looking into County funds for the establishment of a Youth Center and will apply for the funds once the application is available.

2. **ACTION ITEM:** Consideration of direction of staff to review current cost recovery model and research other models to determine best practices. (K. Farro)

Kris Farro, Recreation Manager, introduced this item. Staff is in the process of reviewing the cost recovery and fees for recreational programs. Currently the established fees does not allow for any free or subsidized programming. Staff would like to evaluate the “best practices” for establishing fees to be inclusive for all family.

Other agencies have used the tier model. This method would allow for any entry level or introductory class (lowest tier) to be free or heavily subsidized and specialized classes (highest tier) would not subsidized.

The Commission discussed this topic and agreed to have staff look more into the tier system for the City recreation program fees.

3. **ACTION ITEM:** Approve the City of Brentwood Arbor Day Event on Saturday, April 30, 2022 (J. Coll)

Jason Coll, Park Maintenance Supervisor, met with the Arbor Day ad-hoc committee (Commissioner Cohen & Lind) on March 4, 2022. Jason said the plan is to plant 20 plus trees at Blue Goose Park on April 30th

This will also be the 12th year that the City qualifies to be designated as a Tree City USA.

- ❖ Motion to approve the City of Brentwood Arbor Day Event on Saturday, April 30, 2022.

Motion: Cohen
Second: Lind
Ayes: 4 (Cohen, Frey, Lind, Peltz)
Noes: 0
Excused: 1 (Bullington)

4. **ACTION ITEM:** Approve the recommended conceptual plan for CIP #352-52442 Creekside Park and Garin Park Restrooms. (A. Wanden)

Aaron Wanden, Park Maintenance Manager, is asking the Commission to approve the conceptual plan for CIP #352-52442 Creekside Park and Garin Park restrooms and to be forwarded to the City Council for final approval on April 26.

Aaron met with the ad-hoc committee (Commissioner Lind and Vice-Chair Peltz) to review three updated plans and the committee selected option 3. .

The initial conceptual plans were denied by City Council for aesthetic reasons.

- ❖ Motion to approve option 3 of the conceptual plan for CIP #352-52442 Creekside Park and Garin Park Restrooms.

Motion: Lind
Second: Peltz
Ayes: 4 (Cohen, Frey, Lind, Peltz)
Noes: 0
Excused: 1 (Bullington)

5. **ACTION ITEM:** Approve the recommended conceptual plan for CIP #352-52437 Sunset Park Playground Replacement. (A. Wanden)

Aaron Wanden, Park Maintenance Manager, introduced the item. The ad-hoc committee (Vice-Chair Peltz and Commissioner Lind) met with staff to review conceptual designs submitted by three separate vendors. Park Planet was selected for the project.

Since the initial submittals of conceptual plans, the ad-hoc committee met again on March 15 to review the updated designs and estimate. Upon reviewing the plans, the ad-hoc committee is satisfied with the revisions submitted and seeks approval from the full Commission.

Each element will have its own replacement schedule to be maintained and overseen by the Park Maintenance staff.

- ❖ Motion to approve the recommended conceptual plan CIP #352-52437 Sunset Park Playground Replacement.

Motion: Peltz
Second: Lind
Ayes: 4 (Cohen, Frey, Lind, Peltz)
Noes: 0
Excused: 1 (Bullington)

6. **DISCUSSION/ACTION ITEM:** Discuss and approve the Blue Goose Park Re-opening Ribbon Cutting. (A. Wanden)

Aaron Wanden, Park Maintenance Manager, introduced the item and asked if April 7 at 4:00 pm would be a good time for the Commission to hold the Blue Goose Park Re-opening Ribbon Cutting.

- ❖ Motion to approve the Blue Goose Park Re-opening Ribbon Cutting for April 7, 2022 at 4:00 pm.

Motion: Frey
Second: Cohen
Ayes: 4 (Cohen, Frey, Lind, Peltz)
Noes: 0
Excused: 1 (Bullington)

7. **ACTION ITEM:** Approve the Parkside Villas (Subdivision 8982) Conceptual Park Plan and assign the park name as Trailside Park. (J. Odrzywolski)

Joe Odrzywolski, Parks Planner, introduced the item. On March 14, 2022, the ad-hoc Committee (Chair Frey and Vice-Chair Peltz) met with staff to review the Conceptual Park Plan submitted by the developer, Richmond American Homes. Revisions were made as requested by the committee: add two (2) bench locations along the creek remove some originally proposed BBQ's, relocate a picnic bench area from the middle of the park and provide a shade structure.

The Committee also discussed and considered several park names for this area.

- ❖ Motion to approve the Parkside Villas Conceptual Park Plan and park name Trailside Park.

Motion: Lind
Second: Peltz
Ayes: 4 (Cohen, Frey, Lind, Peltz)
Noes: 0
Excused: 1 (Bullington)

E. REQUEST FOR FUTURE AGENDA ITEMS

I. COMMISSION REQUESTED ITEM(S)

E.1.1. Future agenda item request from Commissioner Cohen for Commission discussion of, and possible direction to staff related to an update to Dolphin Park. (A. Wanden)

Aaron Wanden, Park Maintenance Manager, gave an update on this agenda item as recommended by the City Council. The City Council recommended to keep the weekday hours at Dolphin Park from 11 am – 7 pm and to adjust the weekend hours to 11 am – 2 pm and 5 pm – 7 pm .

Some other recommendations included to have staff work with the Traffic Engineer to have him conduct a feasible study on speedbumps. Staff was asked to update the park matrix to indicate where a reservation permit is required and where bounce houses are allowed.

Commissioner Lind suggested not having Dolphin Park as a monthly agenda item but to have staff give an update on this park every few months. Vice Chair Peltz agreed and Commissioner Cohen said he would be fine leaving this at the staff discretion.

- ❖ Motion to allow staff to give Dolphin Park updates under “Informational Reports from Commissioners, Subcommittees, Liaisons, and Staff” and not a monthly agendized item.

Motion: Cohen
Second: Lind
Ayes: 4 (Cohen, Frey, Lind, Peltz)
Noes: 0
Excused: 1 (Bullington)

II. NEW REQUEST(S) Park and Recreation Commissioners wishing to have an agenda item placed on a future agenda shall make a request under this section of the agenda. These items will be included on the agenda for the next Park and Recreation Commission meeting.

ADJOURNMENT

- ❖ Motion to adjourn the meeting at 8:26 pm.

Motion: Lind
Second: Cohen
Ayes: 5 (Bullington, Cohen, Frey, Lind, Peltz)
Noes: 0

Respectfully submitted,

Elaine McGurk
Administrative Supervisor



PARK AND RECREATION COMMISSION

Norman Cohen, Commissioner
Derrick Bullington, Commissioner

Trevor Frey, Chair

Kevin Peltz, Vice Chair
Blythe Lind, Commissioner

STAFF REPORT

DATE: April 28th, 2022
TO: Park and Recreation Commissioners
FROM: Brian Johnson, Park/Maintenance Supervisor
SUBJECT: Agenda Item #B2
Accept Parks Division Quarterly Report

Parks Maintenance

- Parks staff tested (35) backflow prevention devices in the parks.
- Parks staff has been removing graffiti almost daily at City Park, Brentwood Skate Park and Balfour-Guthrie.
- Parks staff rebuilt the City Park water feature filters in preparation for the spray pad to open April 1st.
- Parks staff got all pump systems for the City's spray pads operational in preparation for the April 1st start date.
- Parks staff converted all bollard lights at City Park to LED lights.
- Parks staff repaired multiple issues at the Oak Meadow restrooms toilets in both Men's and Women's restrooms.
- Parks staff removed many downed trees from various rain/storms this winter.
- Landscape contractors installed 2 new memorial trees in the parks.
- Parks staff removed 18 dead trees in various parks.
- Parks staff replaced multiple sections of sidewalk at King Park.
- Parks staff measured out and striped all sports fields at Sunset, Balfour Guthrie, Oak Meadow and Garin Park.
- Parks staff renovated all baseball fields for the season.

Playground Maintenance

- Construction of the new playground at Blue Goose Park (CIP) is complete and opened to the public.
- Park Maintenance staff has completed 32 Work Orders in regards to playground related issues.
- Park Maintenance staff completed over 100 scheduled playground inspections for the quarter and made all corrections to minor maintenance issues.

- Parks staff replaced various playground parts due to vandalism at Mission Grove, Spirit, Celeste, Granville Green and Walnut Park.

LLD Maintenance

- Park Maintenance staff installed new lettering to the 'Welcome to Historic Downtown Brentwood' sign at the corner of Oak Street and Brentwood Blvd near the Chevron gas station.
- Park Maintenance staff removed and replaced a section of sidewalk on Concord Ave in order to repair an irrigation leak that was under the sidewalk.
- Parks staff completed 10 grinding of tree stumps from dead or removed trees in preparation for new plantings.
- Parks staff and landscape contractors completed over 66 work orders regarding the landscape and irrigation throughout the city's LLD's.
- Landscape contractor completed many plant replacements in LLD 03-2 along O'Hara Ave.
- Parks staff removed many trees in LLD 97-1 in preparation for new plantings.



PARK AND RECREATION COMMISSION

Norman Cohen, Commissioner
Derrick Bullington, Commissioner

Trevor Frey, Chair

Kevin Peltz, Vice Chair
Blythe Lind, Commissioner

STAFF REPORT

DATE: April 28, 2022
TO: Park and Recreation Commissioners
FROM: Mike Azamey, Park Maintenance Supervisor
SUBJECT: Agenda Item #C.3
Accept Maintenance Division Quarterly Report

Landscape construction of Monterosa Park (Shea Homes, Trilogy)



Construction at Alta Park (Shea Homes, Trilogy)



Playground Area at Alta Park (Shea Homes, Trilogy)



Installation of replacement split rail fencing on Concord Avenue due to a single-vehicle accident back in October 2021



Installation of new fencing at Sunset Park around the pinwheel baseball fields.



Silvergate Street Landscaping (Sand Creek Road/O'Hara Avenue)



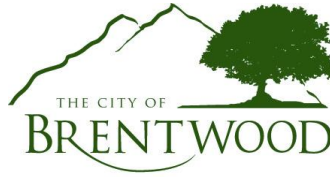

PARK AND RECREATION COMMISSION

Norman Cohen, Commissioner
Derrick Bullington, Commissioner

Trevor Frey, Chair

Kevin Peltz, Vice Chair
Blythe Lind, Commissioner

STAFF REPORT

DATE: April 28, 2022
TO: Park and Recreation Commissioners
FROM: Jason Coll, Park/Maintenance Supervisor
SUBJECT: Agenda Item #B4
Accept Parks Division Quarterly Report

LLAD/R-Area Maintenance/Trees

- Landscape Maintenance contractors corrected approximately 7 Out of Compliance notifications for landscape deficiencies throughout various R-Areas.
- Landscape Maintenance contractors completed 49 work orders related to and R-Area landscape maintenance issues.
- Park Maintenance staff stumpground 17 tree stumps around the city in effort to save money in the contingency of the tree maintenance contract.
- City landscape maintenance contractors replaced 41 plants and 38 trees that failed throughout the city.
- Park Maintenance staff removed 23 dead Redwood trees and stumpground the stumps in preparation for the City of Brentwood's Arbor Day event.
- Park Maintenance staff removed 2 old irrigation controller pedestals that rusted and created a hazard. They were replaced with new stainless steel enclosures that are now up to the City's landscape maintenance standards.
- Park Maintenance crew and supervisors have been working on cleaning up overgrown trees and debris in weed abatement areas to help prevent homeless encampments throughout the city.
- Park Maintenance staff continues to work with Solid Waste, Streets, Water and Community Enrichment on the citywide tree matter to ensure they are up to the City of Brentwood's municipal codes.
- Park Maintenance staff is working on correcting the effects of the City's non-potable water on the soil and plant health. The Park Maintenance Supervisor is working with different soil amendments and maintenance techniques that could minimize the negative effects caused by irrigating with non-potable water.
- Park Maintenance staff continues to respond to emergencies, remove, trim and maintain the City's 30,000+ trees in effort to alleviate the high cost of tree maintenance on the City of Brentwood.



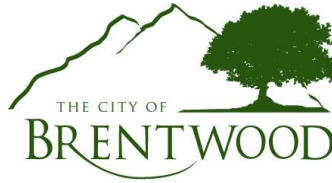

PARK AND RECREATION COMMISSION

Derrick Bullington, Commissioner
Norman Cohen, Commissioner

Trevor Frey, Chair

Kevin Peltz, Vice Chair
Blythe Lind, Commissioner

STAFF REPORT

DATE: April 28, 2022

TO: Park and Recreation Commissioners

FROM: Kris Farro, Recreation Manager

SUBJECT: Agenda Item #C.1
Discuss and consider approval of Sunset Park Athletic Complex change of hours of operation and any additional relative considerations.

Staff will provide an update on the status of the Sunset Park Athletic Complex Strategic Initiative to increase hours of operation. The Commission will discuss the project update and any additional items to be considered as part of this project. The Commission will consider approval of Sunset Park Athletic Complex change of hours of operation and any additional relative considerations.

Background

On October 9 and 10, 2019 the City Council participated in a strategic plan workshop to discuss the City of Brentwood draft Strategic Plan FY 2020/21 – FY 2021/22, and to direct staff on various initiatives. The City Council received financial information related to the City's financial capacity and identified resources to fund the two-year strategic plan. During the workshop, the City Council discussed, reviewed, and provided staff with direction on various initiatives.

On February 25, 2020, the City Council adopted Resolution 2020-29 to a) adopt the City of Brentwood Strategic Plan FY 2020/21 – FY 2021/22, and b) direct staff to incorporate strategic plan costs into the Operating and Capital Improvement Program (CIP) Budgets, as well as in the City's ten-year General Fund Fiscal Model. The Strategic Plan included the following initiative in Focus Area 5: Community and Neighborhood Services:

1. Implement short-term high priority Parks and Recreation Master Plan projects:
 - c. Increase Sunset Park Athletic Complex hours of operations

On May 26, 2020, the City Council conducted a workshop on the draft 2020/21 – 2021/22 Operating Budget and draft General Fund Fiscal Model.

On June 23, 2020, the City Council adopted Resolution 2020-85 amending the 2019/20 Operating Budget and adopting the 2020/21 – 2021/22 Operating Budget.

On July 14, 2020, the City Council adopted Resolution 2020-96 to amend the City of Brentwood Strategic Plan FY 2020/21 – FY 2021/22. The Strategic Plan included the following initiative in Focus Area 5: Community and Neighborhood Services:

1. Implement short-term high priority Parks and Recreation Master Plan projects:

e. Increase Sunset Park Athletic Complex hours of operations

On January 26, 2021, the City Council adopted Resolution 2021-15 amending the 2020/21 Operating Budget; approving the recommended mid-year budget adjustments; and amending the 2020/21 – 2024/25 Capital Improvement Program (CIP).

On February 9, 2021, the City Council received an update on the Amended City of Brentwood Strategic Plan FY 2020/21 – FY 2021/22 and Funding Deferred Projects Holding List.

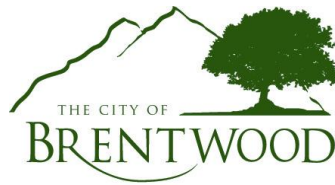

PARK AND RECREATION COMMISSION

Derrick Bullington, Commissioner
Norman Cohen, Commissioner

Trevor Frey, Chair

Kevin Peltz, Vice Chair
Blythe Lind, Commissioner

STAFF REPORT

DATE: April 28, 2022

TO: Park and Recreation Commissioners

FROM: Joe Odrzywolski, Park Planner

SUBJECT: Agenda Item #C.2
Approve the formation of an ad-hoc committee for the Creekside Pickleball Court
CIP Project #352-52441

Staff is requesting the Commission choose two committee members and approve the formation of an ad-hoc committee for the Creekside Pickleball Court CIP Project #352-52441.

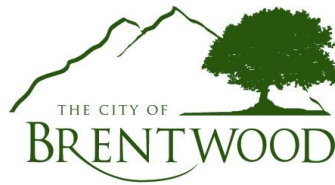

PARK AND RECREATION COMMISSION

Derrick Bullington, Commissioner
Norman Cohen, Commissioner

Trevor Frey, Chair

Kevin Peltz, Vice Chair
Blythe Lind, Commissioner

STAFF REPORT

DATE: April 28, 2022

TO: Park and Recreation Commissioners

FROM: Joe Odrzywolski, Park Planner

SUBJECT: Agenda Item #C.3
Approve the formation of an ad-hoc committee for the Sand Creek Sports Complex project.

Staff is requesting the Commission choose two committee members and approve the formation of an ad-hoc committee for the Sand Creek Sports Complex project.

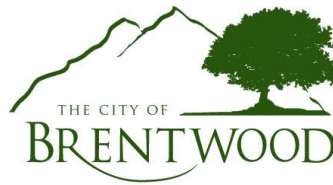

PARK AND RECREATION COMMISSION

Derrick Bullington, Commissioner
Norman Cohen, Commissioner

Trevor Frey, Chair

Kevin Peltz, Vice Chair
Blythe Lind, Commissioner

STAFF REPORT

DATE: April 28, 2022

TO: Park and Recreation Commissioners

FROM: Joe Odrzywolski, Park Planner

SUBJECT: Agenda Item #C.4
Provide direction to staff regarding the park acreage requirement for the 7590 and 7650 Lone Tree Way project, Subdivision 9597, a proposed 38-lot single-family residential subdivision.

Staff is seeking direction from the Commission as to whether this project should include a park dedication and build a park with the project at the General Plan prescribed rate of 5 acres per 1000 residents, or pay in-lieu fees (fee out) per the Development Fee Program.

Seecon Financial and Construction Company is proposing a 38-lot single-family residential subdivision at 7590 and 7650 Lone Tree Way, a 16.3 acre site. With the official application submittal made to the Planning Department recently, no park dedication is proposed by the developer currently and the project as proposed would pay an in-lieu fee of approximately \$435,000 in Development Impact Fees for Parks and Trails. See the attached Vesting Tentative Map Exhibit.

Staff has concerns about the project not providing equitable park access for the project's new residents and is considering requiring the project to dedicate the requisite park acreage, approximately 0.60 acres of park, within the project. The project's location would require new residents to travel a distance of almost a half-mile (2,640 feet) AND cross the busy arterial streets of Lone Tree Way or O'Hara Avenue in order to access existing parks. Per the 2019 Parks, Trails and Recreation Master Plan, in determining park dedication requirements for new development, residents of the new development should have easy, safe access to an existing park within a half-mile walk. See attached exhibit and summary below.

Portofino Park – 2000+ feet, requires crossing Lone Tree Way at either O'Hara or Adams Lane, lacks sidewalks in some areas along Lone Tree Way. Passive park with no play structure.

Steeplechase Park – 2000+ feet, requires crossing O'Hara, lacks sidewalks in some areas along Lone Tree Way. Does include play structure.

Pistachio Park – 2000+ feet, requires crossing O'Hara, lacks sidewalks in some areas along Lone Tree Way. Does include play structure.



800.0 0 400.00 800.0 Feet

NAD_1983_StatePlane_California_III_FIPS_0403_Feet

This map is a user generated static output from an Internet mapping site and is for reference only. Data layers that appear on this map may or may not be accurate, current, or otherwise reliable.

THIS MAP IS NOT TO BE USED FOR NAVIGATION

Notes:

1: 4,800



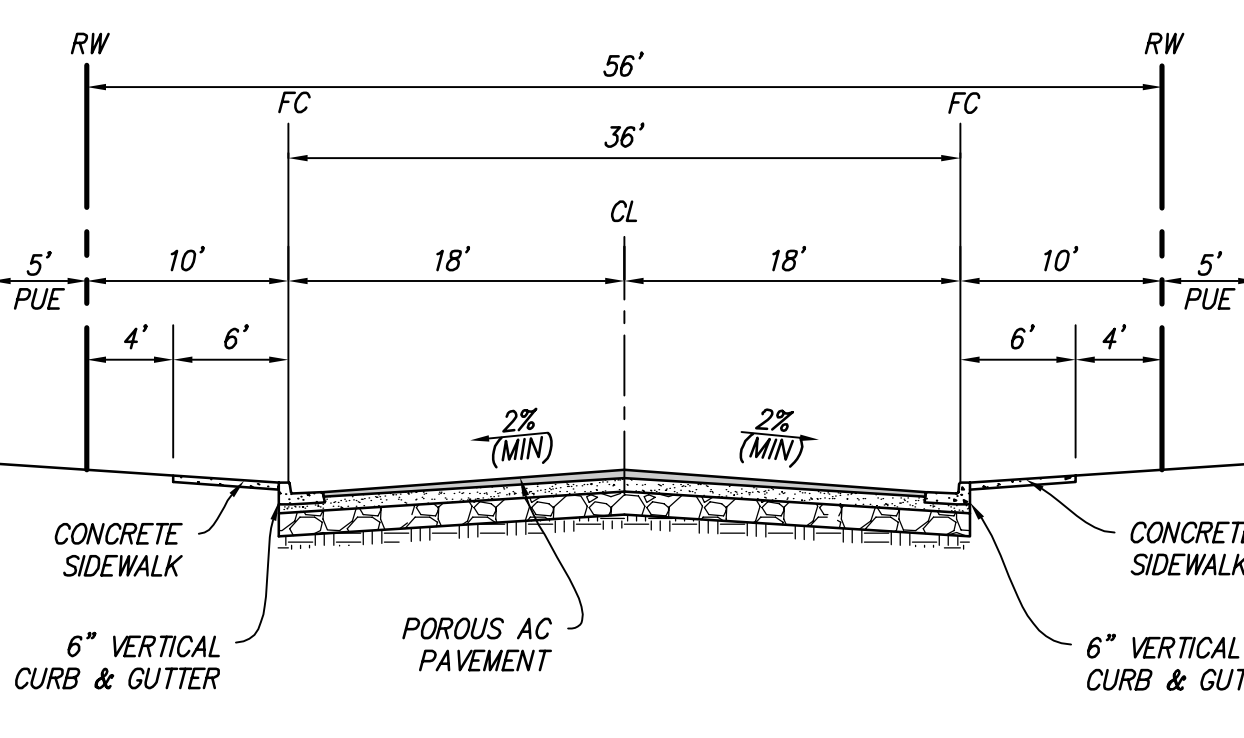
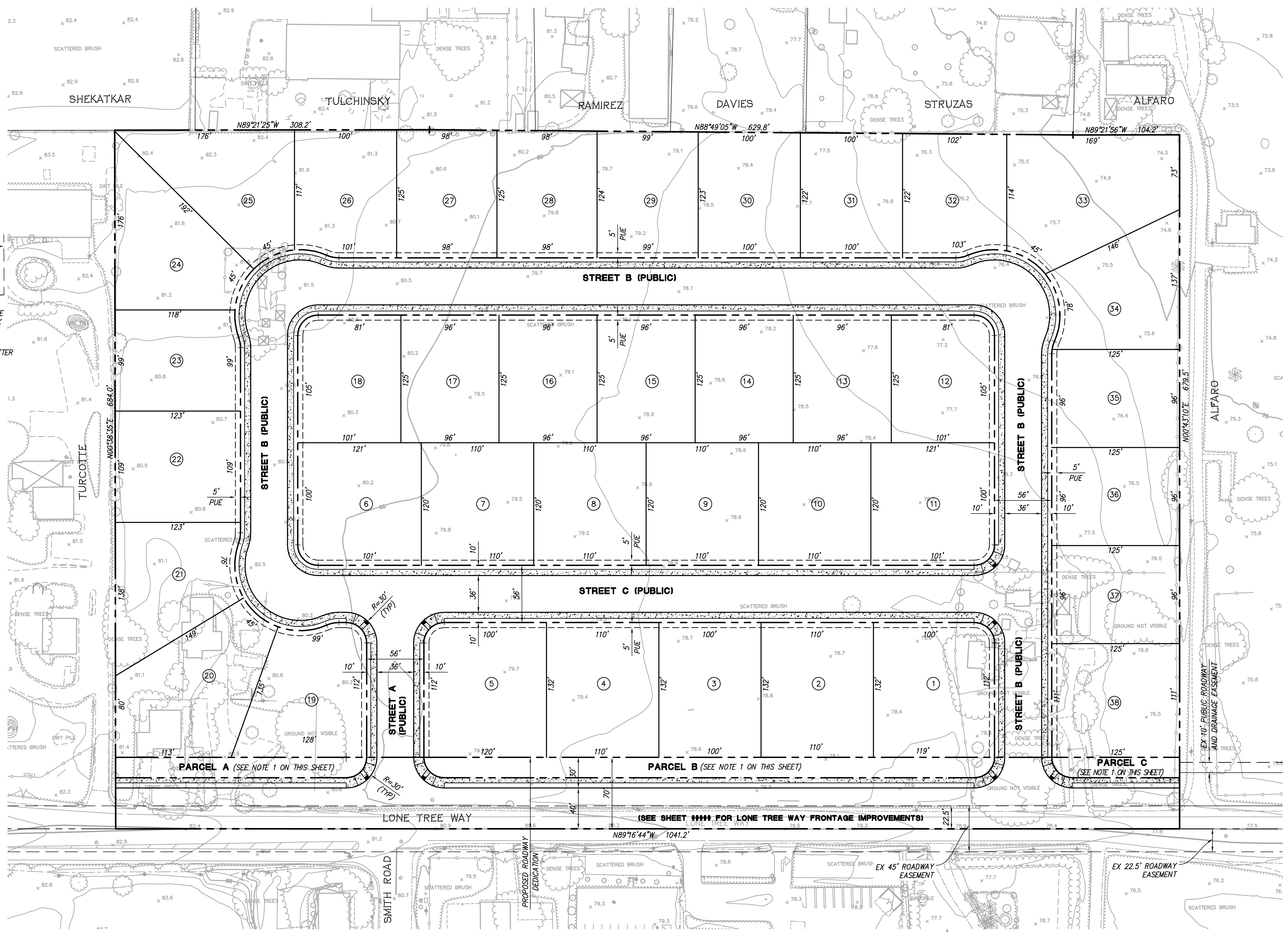

NOTE: RESIDENTIAL DRIVEWAYS PER CITY STANDARD ST-7A

STREETS A, B, & C
NOT TO SCALE

- NOTE:
1. PARCELS A, B, & C ARE OPEN SPACE PARCELS TO BE OWNED AND MAINTAINED BY THE CITY AS A PART OF THE DEDICATED LONE TREE WAY PUBLIC STREET RIGHT OF WAY.
 2. ALL ON SITE STREETS A, B, & C ARE TO BE PUBLIC STREETS TO BE OWNED + MAINTAINED BY THE CITY.

LOT AREA TABLE	
LOT #	AREA (SF)
1	15,564
2	14,520
3	13,200
4	14,520
5	15,754
6	14,434
7	13,200
8	13,200
9	13,200
10	13,200
11	14,434
12	12,539
13	12,000
14	12,000
15	12,000
16	12,000
17	12,000
18	12,539
19	13,974
20	16,523
21	13,663
22	13,372
23	12,032
24	14,139
25	14,273
26	12,316
27	12,272
28	12,199
29	12,245
30	12,288
31	12,207
32	12,106
33	18,346
34	13,084
35	12,000
36	12,001
37	12,000
38	13,903
PARCEL A	4,829
PARCEL B	10,999
PARCEL C	2,414

PRELIMINARY LOTTING PLAN
SUB 9597 - 7590 & 7650 LONE TREE WAY

CITY OF BRENTWOOD, CONTRA COSTA COUNTY, CALIFORNIA
FOR: SECON FINANCIAL & CONSTRUCTION CO.

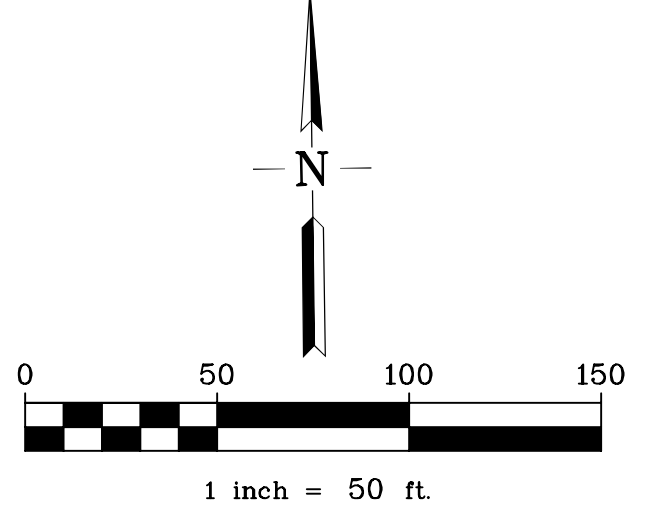

RJA
RUGGERI-JENSEN-AZAR
ENGINEERS • PLANNERS • SURVEYORS
4690 CHABOT DRIVE, SUITE 200 PLEASANTON, CA 94588
PHONE: (925) 227-9100 FAX: (925) 227-9300

C:\JOB2021\211071\CAD FILES\02-PLANNING\TEXT-MAP1\MLG.DWG - 2/23/2022 3:51:49 PM WML BARTALINI