

RECEIVED  
MAR 09 2006  
CITY OF BRENTWOOD  
COMMUNITY DEVELOPMENT DEPT.



# VALVERDE PLAZA

## SIGN GUIDELINES

BRENTWOOD CALIFORNIA

CITY OF BRENTWOOD  
104 OAK STREET

THESE PLANS ARE APPROVED SUBJECT TO THE FOLLOWING  
CONDITIONS

ONE COPY OF THESE APPROVED PLANS MUST BE ON THE JOB SITE  
AND AVAILABLE FOR REVIEW AT ALL TIMES

ANY CHANGES OR ALTERATIONS TO THESE PLANS AND SPECIFICATIONS  
MUST BE SUBMITTED TO THE CITY OF BRENTWOOD FOR APPROVAL

THE APPROVAL OF THESE PLANS DOES NOT RELIEVE THE  
CONTRACTOR, OWNER OR CRAFTSMAN OF ANY VIOLATION OF THE  
PROVISIONS OF THE UNIFORM CODES OR ANY CITY ORDINANCE  
WHICH MAY BE CONTAINED WITHIN

BUILDING \_\_\_\_\_ DATE \_\_\_\_\_

PLANNING \_\_\_\_\_ DATE \_\_\_\_\_

CITY / Planning



superior  
electrical advertising

1700 West Anaheim Street  
Long Beach, California  
90813-1195  
phone: 562.495.3808  
facsimile: 562.435.1867

# APPROVED

BY: Winston Rhodes

DATE: 3/9/06

DR 01-22

## VALVERDE PLAZA SIGN OBJECTIVES AND REQUIREMENTS

Welcome to Valverde Plaza,

Enclosed are various sign designs and requirements for construction and placement. These signs are carefully designed to enhance the Plaza's identity in the City of Brentwood's Downtown district and to identify the tenants location and services.

All signs are to conform to the guidelines set forth in this program.

Tenants are not to deviate from color, fabrication or location of installation of any sign type.

All signs have been designed according to the City of Brentwood sign code. The City of Brentwood and Valverde Plaza Management are responsible for any and all approvals.

Tenants are responsible for presenting details of the signage they qualify for. Prior to fabrication or installation; details are to be presented to the Valverde Plaza Management team for approval. Tenants are than required to apply with the City of Brentwood for final approval.

## SUPPLIER REQUEST

Valverde Plaza has been designed with uniform signage for each area of the plaza.

To insure the continuity with the fabrication of these signs we request that you contact a qualified fabricator for theses signs.

Contact your property manager or landlord for approved vendor assistance.



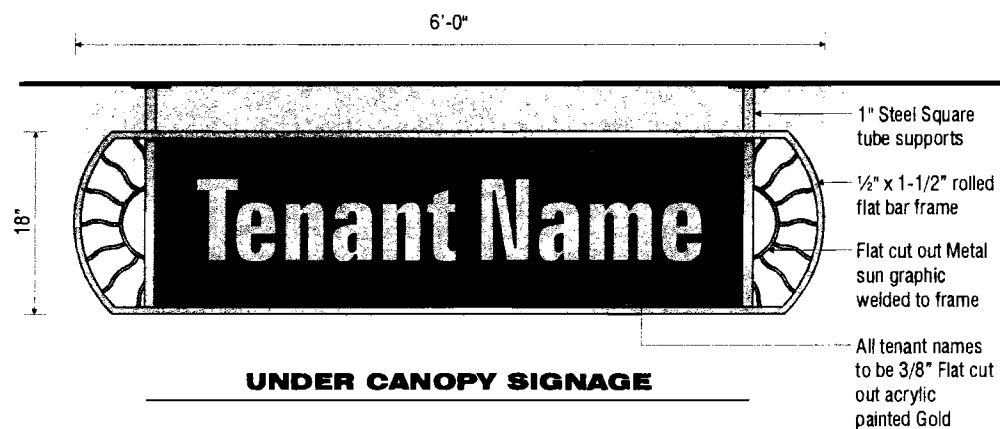

**UNDER CANOPY SIGNAGE**

**SPECIFICATIONS**

Manufacture & install double-face, non-illuminated under canopy signs.  
( Exact quantity to be determined )

SIGNS ARE DESIGNATED FOR SECOND STREET FRONTAGE ONLY  
 SIGNS ARE TO BE LOCATED AS DIRECTED IN THESE GUIDELINES  
 4 SIGNS TOTAL WILL BE PERMITTED FOR THE SECOND STREET FRONTAGE  
 ONE SIGN TOTAL MAX PER QUALIFYING TENANT  
 SIGNS MAY NOT BE SPLIT BETWEEN TENANTS

**SIGN TYPE A: EXTERIOR UNDER CANOPY SIGN**

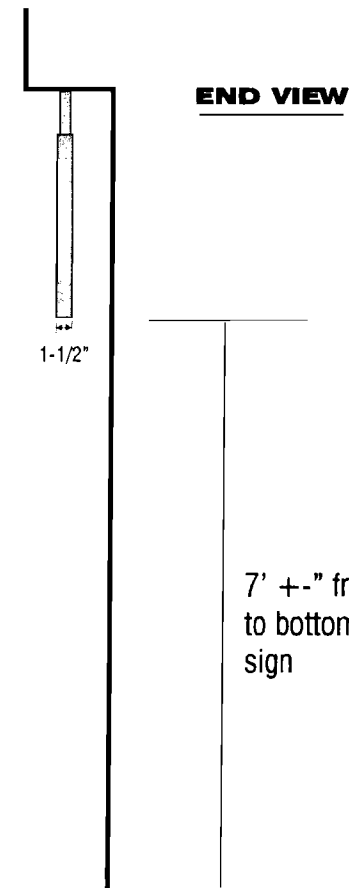

**SECONDARY SIGNAGE**

SCALE : 1/2" = 1'



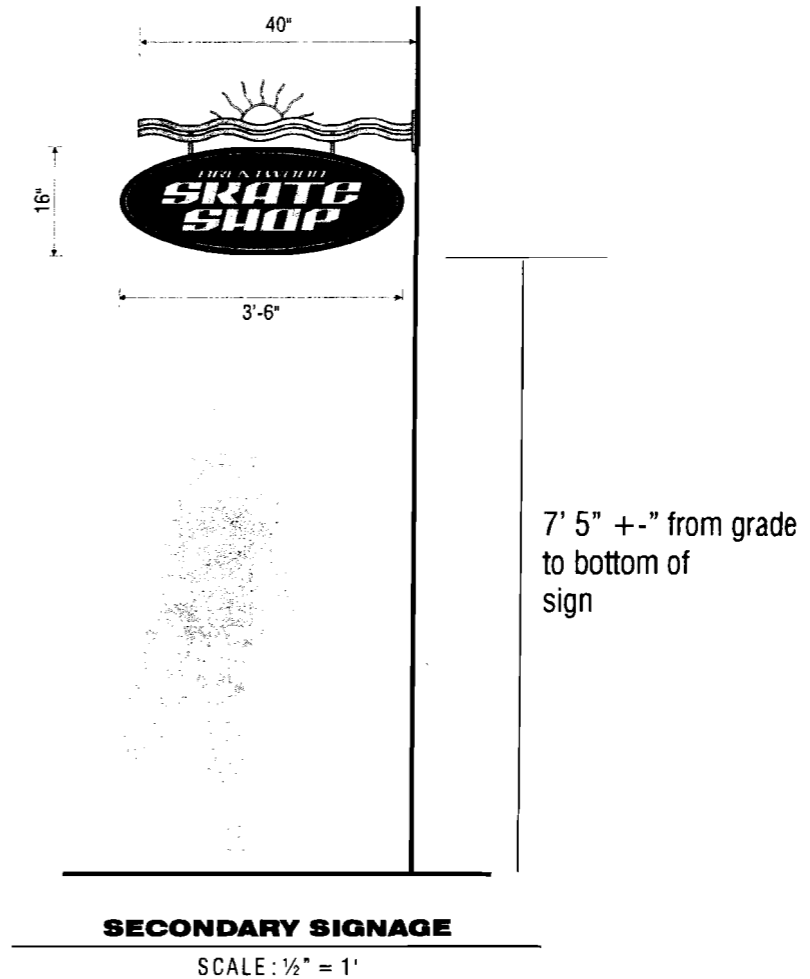
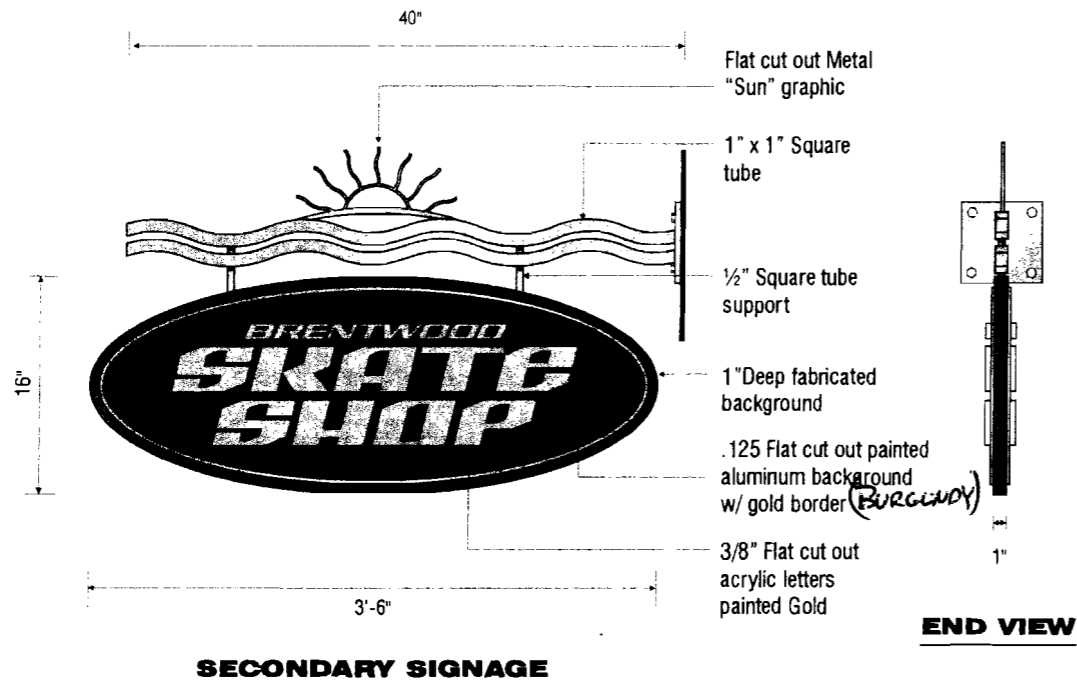

SIGNS ARE DESIGNATED FOR THE COURTYARD ONLY  
 SIGNS ARE TO BE LOCATED DIRECTLY OVER EACH  
 ESTABLISHMENTS ENTRY OFF OF THE COURTYARD  
 FOUR SIGNS TOTAL WILL BE ALLOWED IN THE COURTYARD  
 SIGNS MAY NOT BE SPLIT AMONG TENANTS  
 ALL SIGNS ARE NON-ILLUMINATED.

**SIGN TYPE B: COURTYARD PROJECTING SIGN**



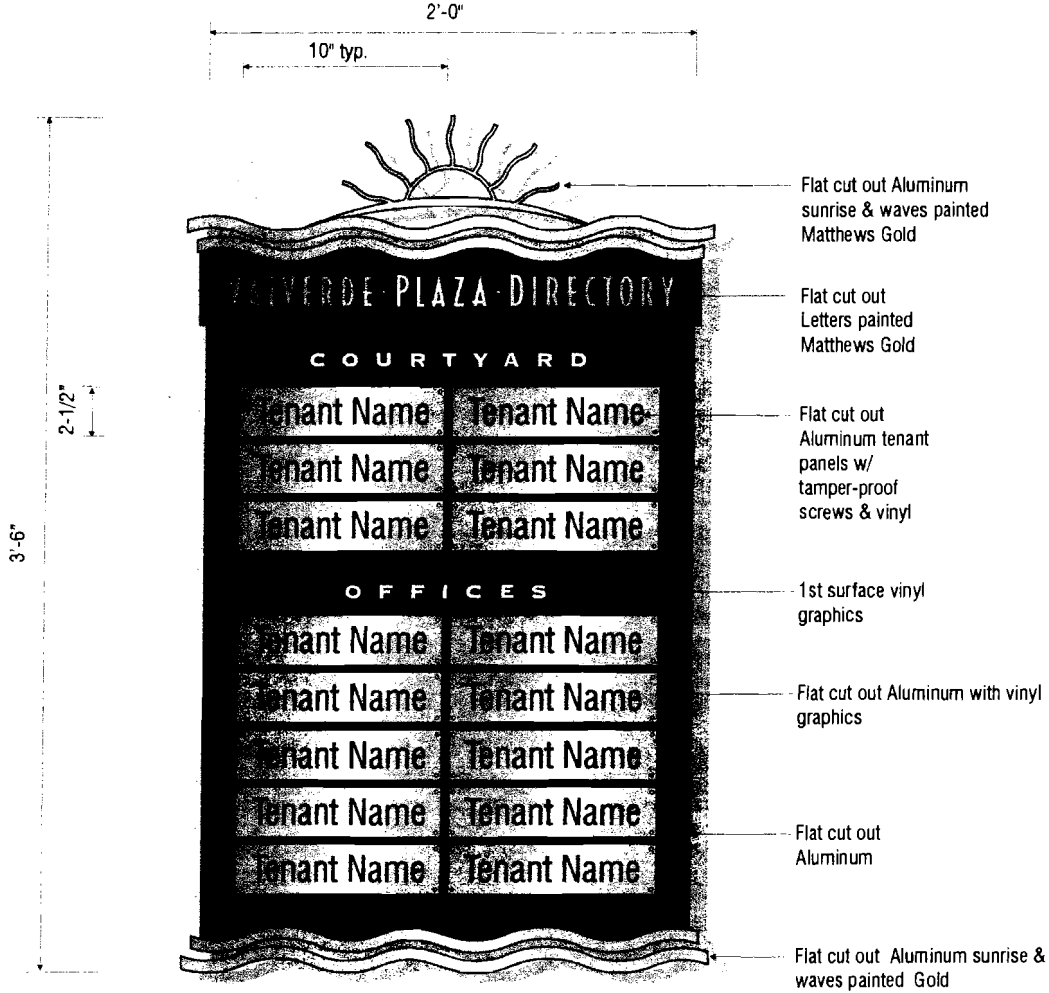

**DIRECTORY SIGNAGE**

SCALE: 1-1/2" = 1'

**SPECIFICATIONS**

Manufacture & install single-face, non-illuminated directory sign.  
 One Directory to be installed on the front elevation at the courtyard entry As seen in elevation.  
 One Directory sign may be allowed at the back entrance for addition direction if needed.  
 Location of back entrance directory sign to be approved by planning prior to install.

**SIGN TYPE 3: EXTERIOR DIRECTORY SIGN**

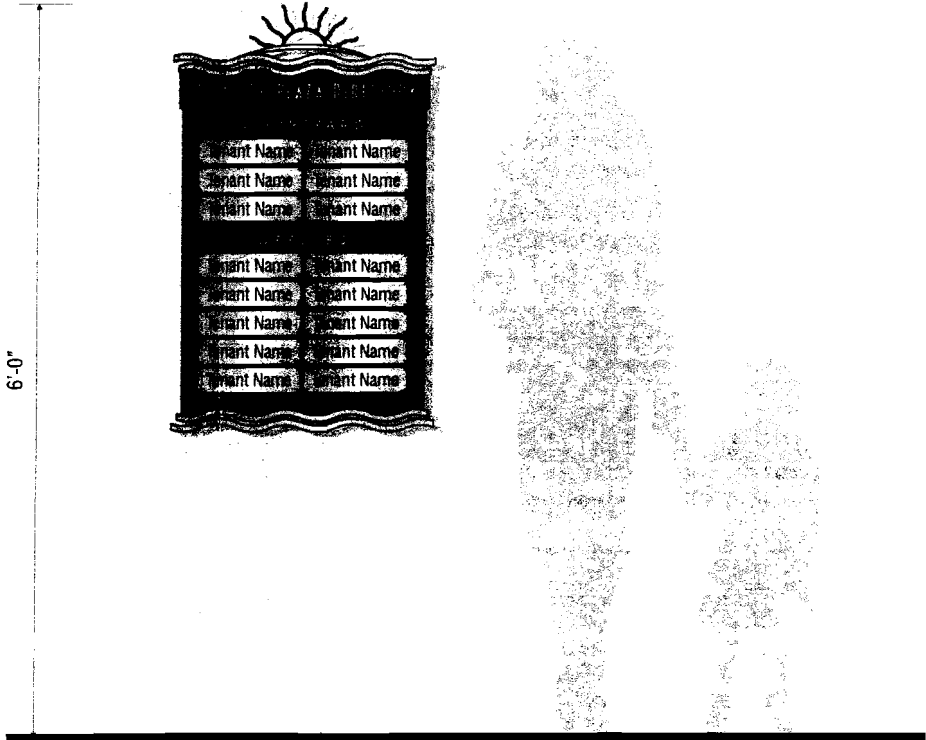

**TYPICAL ELEVATION**

SCALE: 3/4" = 1'

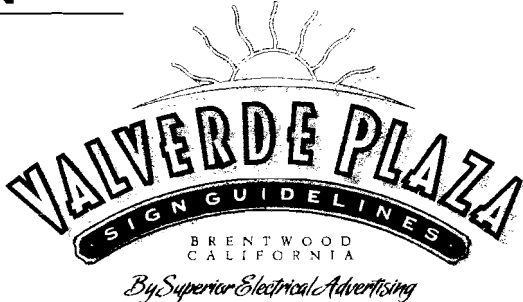

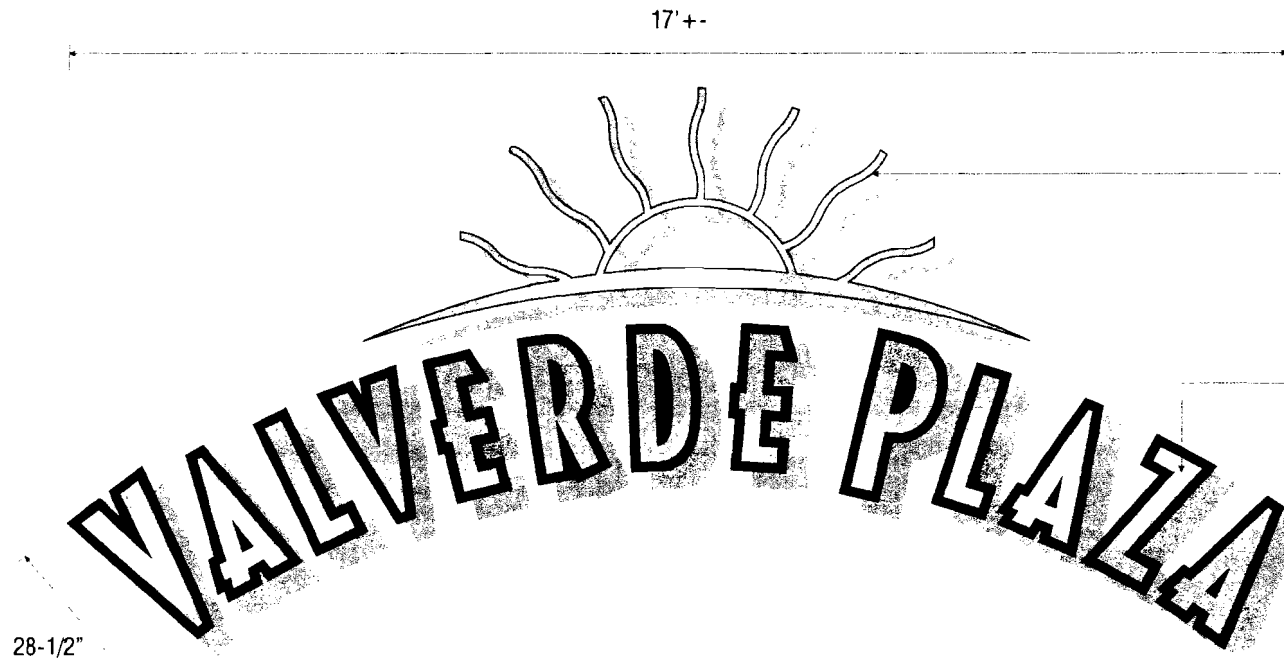

"Sunrise" logo to be 1/2" thick Acrylic painted black w/ brushed gold Wrisco applied to face & pegged-off wall 1/2"

Letters to be 1/2" thick acrylic painted black w/ brushed gold Wrisco applied to face & mounted to .125 Flat cut out burgundy painted aluminum background. Letters to be pegged-off wall 1/2"

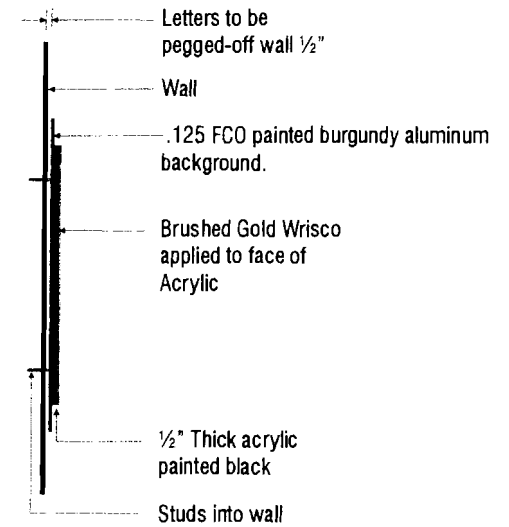

**MAIN ENTRANCE SIGNAGE**

**SPECIFICATIONS**

Manufacture & install one ( 1 ) single-face, non-illuminated wall sign

**MOUNTING  
DETAIL - LETTERS**

SCALE : 3/4" = 1'

**SIGN TYPE D: EXTERIOR DIRECTORY SIGN**



## COLOR REQUIREMENTS

---

All Sign devices are to be finished with the following colors.  
Each element from each sign has designated colors.  
Use this color chart to determine exact finish and color match requirements.

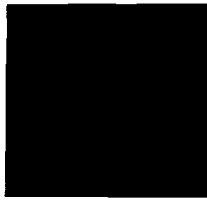

Burgundy  
Satin Polyurethane  
Finish  
To Match 3M 3630-49  
Or  
Pantone 188

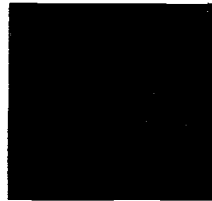

Dark Emerald Green  
Satin Polyurethane  
Finish  
To Match 3M 3630-26  
Or  
Pantone 3435

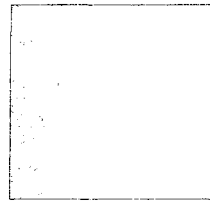

Gold Metallic  
Satin Polyurethane  
Finish  
To Match 3M  
3630-131  
Or  
Pantone 873

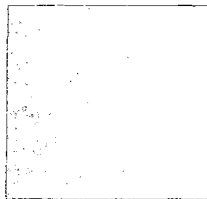

Brushed Gold Wrisco  
Horizontal Grain



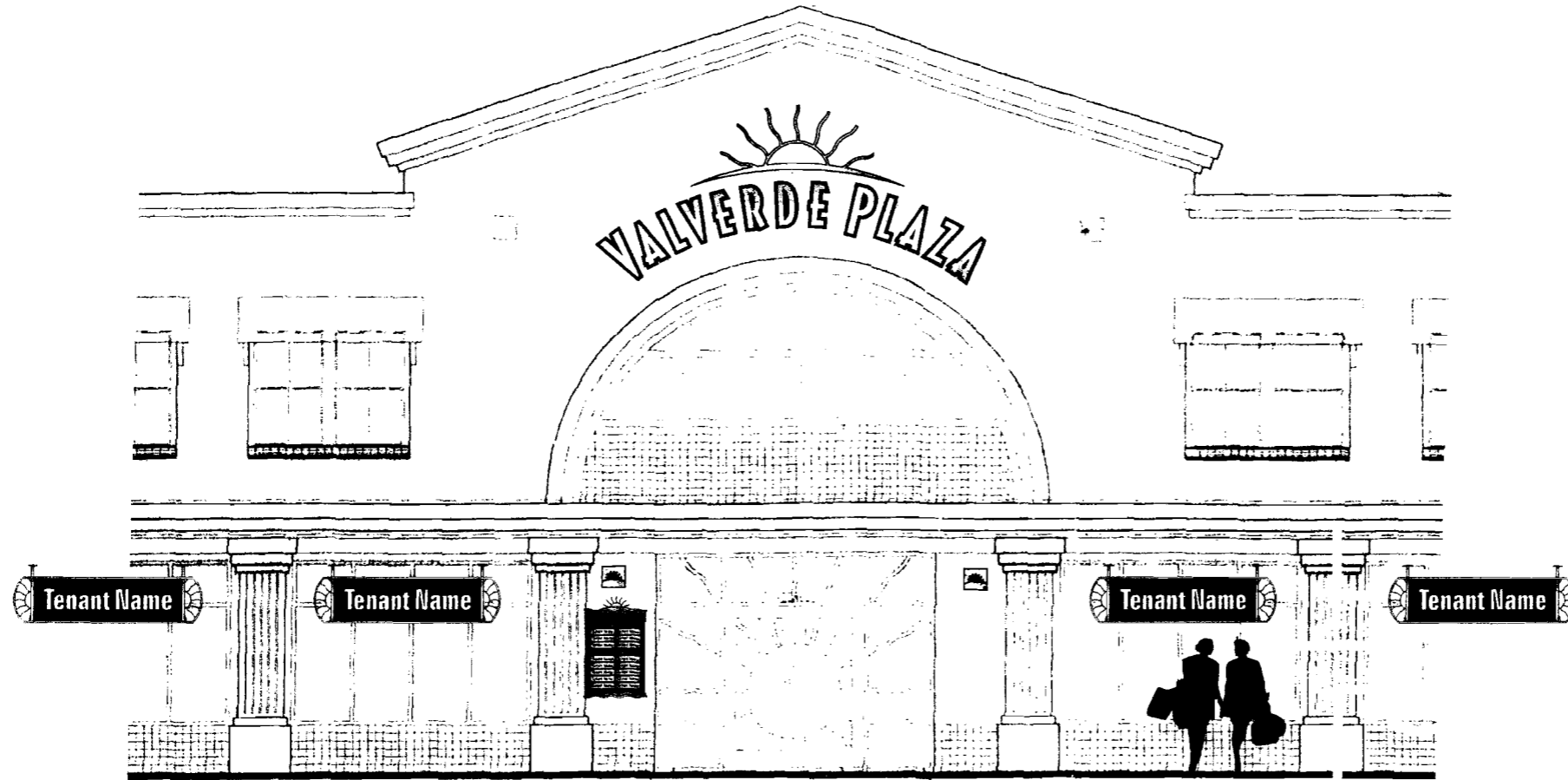

MAIN ENTRANCE ELEVATION

EXTERIOR ELEVATION OPTION 1

